

# Pressure To Current Converter v4 PIC246

## DESCRIPTION

The PIC246 is a loop-powered transmitter for use in applications that require electronic pressure monitoring. Both differential pressure and gauge pressure versions are available. The PIC246 offers an economical solution combining compactness with accuracy and flexibility. Standard output is 4 - 20mA with a minimum supply voltage of 7V. This enables the PIC246 to be used in 12V battery supply systems or in automotive applications. Other factory set output configurations are 10 - 50mA loop powered and 0 - 10mA, 0 - 20mA or voltage output in 3-wire connection. Reference for 3-wire connection is the negative supply. The heart of the unit is a piezo resistive silicon pressure transducer, providing high accuracy, long life and total adjust-ability. Double surge protection is standard with all Series 200 loop powered transmitters to prevent failure due to spikes induced by DC switched inductive loads. Final calibration is trimmed using the front accessible zero and span 15-turn trim adjustments. A front mounted LED and a test socket verify module function and assist in calibration checks without disconnection of output wires.



## General Specifications

Mounting:	Clip for 35mm DIN-Rail
Case size:	23.5W x 71.5H x 109D (mm).
Case material:	ABS.
Connection:	Screw terminals.
Weight:	0.100 kg.
Protection class:	IP40. (IP65 use suitable enclosure).
Input pressure ranges:	2kPa up to 0 - 200kPa. (200mmWG up to 20mWG).
Medium compatibility:	Air, low pressure steam, gasoline and oil vapours, ethylene glycol.
Over pressure (max):	100kPa (all ranges).
Static pressure:	100kPa.
Accuracy:	<1% of range (2% <2kPa range).
Front 'SPAN' adjust:	±25% typical.
Front 'ZERO' adjust:	+20/ -10% typical.
Linearity:	±1% of range.
Pressure hysteresis:	0.05% of range.
Temperature drift:	0.02% per °C.
Supply voltage:	7 - 40V continuous (50V 30 seconds).
Load for 4 - 20mA output:	$RL_{max} = \frac{SupplyVoltage - 7V}{0.02A} \Omega$
Load change effect:	0.1% up to RL max.
Electromagnetic compatibility:	Complies with AS/NZS 4251.1 (EN 50081.1)

## Block Diagram

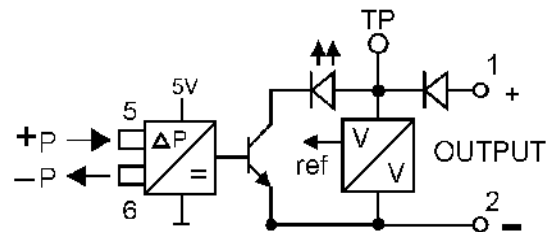

For input / output combinations refer to TYPE NO. DESIGNATION overleaf.

## TYPE NO. DESIGNATION

PIC246 - X X X X X

### Output:

- 1 = 4 - 20mA.
- 2 = 10 - 50mA.
- \*) 3 = 0 - 1mA.
- \*) 4 = 0 - 10mA.
- \*) 5 = 0 - 20mA.
- \*) 6 = 0 - 1V.
- \*) 7 = 0 - 5V min supply 10.5Vdc.
- \*) 8 = 0 - 10V min supply 15.5Vdc.
- \*) 9 = Other (Specify).

### Input:

- 3 = 1 to 10kPa (specify calibration).
- 6 = 10 to 100kPa (specify calibration).
- 8 = 100 to 200kPa (specify calibration). Select 9 when using measurement 3 below.

### Nozzle Type:

- 1 = Barbed fitting for 3.5 - 4mm ID soft tube.
- \*) 2 = Quick-Connect 3.2mm (1/8") OD tube (recommended tube SMC TE 1800 BG)
- \*) 6 = Quick-Connect 6mm OD tube
- \*) 7 = 1/4" NPT female

### Measurement:

- 1 = Gauge pressure.
- \*) 2 = Differential pressure.
- \*) 3 = 0 - 120 kPa absolute (barometric).

### Options:

- 0 = None.
- \*) 2 = Output ramp.
- 3 = Reverse action.
- \*) 9 = Other (Specify).

\*) = Price Extra.

## Front Control Explanation

1. Test socket. Output signal access with reference to terminal (1) loop integrity is maintained when digital multi meter Rin < 30Ω is used.
2. Loop indicator. Dim at 4mA, bright at 20mA.
3. SPAN (full scale) adjustment 15 turn.
4. ZERO (start scale) adjustment 15 turn.

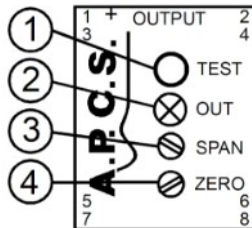

### Wiring Example

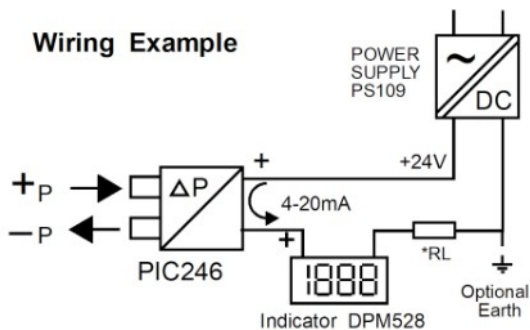

\*Note: RL is input load of PLC, VSD, or other process instruments.

### Connection Diagrams

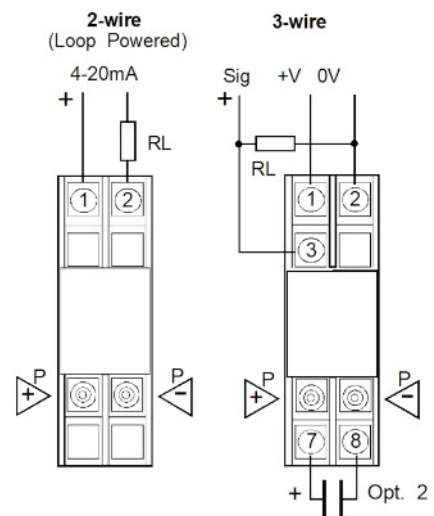

Inputs labelled P- are only fitted on differential models.

In the interest of development and improvement, APCS reserve the right to amend, without notice, details contained in this publication. APCS will accept no legal liability for any errors, omissions or amendments.