

LUX Transmitter v3 LUX510

DESCRIPTION

The LUX510 is a loop powered LUX or light intensity transmitter. The durable IP65 enclosure is ideally suited for stand-alone mounting anywhere in or around unprotected plant equipment. A gland is provided for output cabling. Standard output is 4 to 20mA with a minimum supply voltage of 6.3V. Typical applications include curtain control in areas such as greenhouses. Output zero and SPAN adjustment are located on the PC-board.



GENERAL SPECIFICATIONS

Size:	65 x 94 (116 with gland) x 58D (mm)
Mounting:	4 holes 4mm diameter 79 x 50 under cover screws.
Housing material:	ABS base / Poly-carbonate cover.
Connection:	Terminal blocks / 0.5 - 1.5mm ² .
Cable entry:	Cable gland UA12 (12mm).
Protection category:	IP65.
Weight:	0.22 kg.
Calibration accuracy:	< 5% of range.
Operating temperature range:	-10...+65°C.
Temperature drift error:	<0.5% within operating range.
Supply voltage:	6.3-40V continuous (50V 30 seconds).
Load for 4-20mA output:	$RL_{max} = \frac{SupplyV - 6.3V}{0.02A} \Omega$
Load change effect:	0.1% up to RL max.
Response time:	0.2 sec for T90.
Out zero adjustment:	+20% / -10%.
Span adjustment:	±25%.
Input range:	0 - 140000 LUX.
Electromagnetic compatibility:	AS IEC 62040-2: 2019

Calibration

The unit is factory set to customer specification however the unit may be changed using the link header. 1000 LUX is set by removing all links. Other settings can be achieved by fitting up to two links (Fit lings 2 and 5 fro7000 LUX).

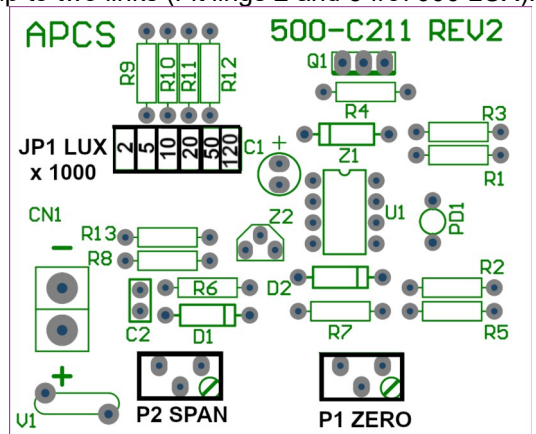

Use zero and span for final calibration. Changing ranges without timing to a standard will add a possible 2% error. When trimming replace the lid to recheck the result. When using very low light ranges ensure absolute dark when setting the zero.

TYPE NO. DESIGNATION

Output: _____

1 = 4 - 20mA 2-wire.
 2 = 10 - 50mA 2-wire. *) 9 = Other specify.

LUX510 - X X 30

Input: _____

*) 1 = Link Selectable. 1000, 2000, 5000, 10000, 20000, 50000, 120000 LUX.

Connection Example

The LUX510 is a loop powered transmitter. *RL shown represents the input load of a PLC, or other process instrument.

Lid Seal

Do not over tighten lid as this will damage the gasket. The lid is not designed to be a flush fit on the box. If re-sealing check that the gasket is in good condition. The lid screws should be tightened progressively around the lid. To prevent moisture build-up around the cable gland smear cable and lid gasket with a film of Vaseline Petroleum Jelly.

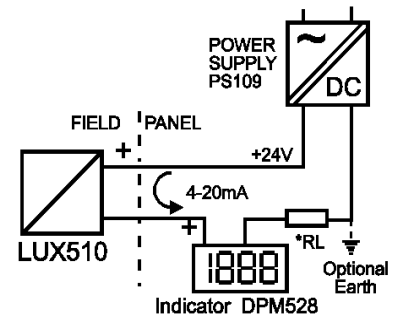

*) = Price Extra.

In the interest of development and improvement, APCS reserve the right to amend, without notice, details contained in this publication. APCS will accept no legal liability for any errors, omissions or amendments.