

DESCRIPTION

The DUAL ISOLATOR DI739 combines two fully independent isolator channels in one housing. Optional 10A rated trippoint for monitoring and alarming is available on channel 2.

The DI739 can be used in a number of ways:

- Two channel isolation and any mix of signals.
- Isolation and conditioning of two field sensors.
- Signal splitting (one input and two isolated outputs).
- Range splitting where output 1 responds to 0-50% of input, output 2 to 50-100% of input.

The inputs are factory configured to customer requirement. Both outputs are coding plug configurable for common process signals (Factory default is 4-20mA out). Final calibration can be trimmed by using the front accessible SPAN (S) and ZERO (Z) potentiometers. The optional alarm point on channel 2 is also set by potentiometer utilising the adjacent test socket. The voltage at the test socket (referenced to terminal 13) gives a 0-5V trip set range representing 0-100% input. The wide swing DC/DC converter allows for two power supply ranges: 10-60Vdc (16-42Vac), 80-280Vac (80-300Vdc). Isolation is 2kV.r.m.s. between all 6 ports. Connection is via unpluggable 8-way screw terminals.



General Specifications

Mounting: 35mm DIN-Rail.
 Termination: Plug-in screw terminals.
 Weight: 0.300 kg.
 Protection class: IP40 (IP65 Enclosure optional).
 Size: 60W x 70H x 110D (mm).
 Housing material: ABS, aluminium.
 Calibration accuracy: <0.2% of range.
 Auxiliary Supplies: 19V/22mA fitted on all inputs except:

- (36) Frequency NAMUR/Contact =5V
- (42) Potentiometer =5V
- (34) RTD (3 wire connection)

Ambient temperature

Operating range: 0...+60°C.
 Storage temp. range: -20...+70°C.
 Temperature effect: 0.02% per °C.
 Output drive: 0 to 22mA (20V drive).
 0 to 20V (100 kΩ min)

Response time: 500ms standard (5ms link).
 Zero/Span adjust: Typically ±20%
 Contact rating: 10A/250Vac resistive.
 Trip repeatability: <0.5% of range.
 Trip response time: <100ms.
 Switching hysteresis: 1 to 25% of input range.
 Factory set 1%.

Power requirements: 4VA.
 6-way Isolation: 2kV r.m.s.
 Electromagnetic compatibility: Complies with AS/NZS 4251.1 (EN 50081.1)

To change output ranges:

- 1) Disconnect power to unit.
- 2) Unscrew right-side cover and withdraw PCB assembly.
- 3) Set the coding plugs as required.
- 4) Reassemble unit and connect power.
- 5) Adjust "span" and "zero" pots to recalibrate.
- 6) Change the label information to the new input/output values.

Block Diagram

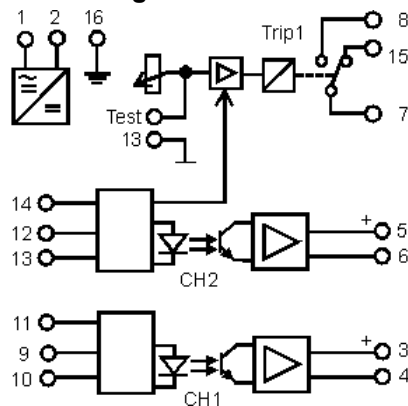

Changing ranges

All input calibrations are factory configured. All output selections are on the C204 PCB, SW1 is for channel 1, SW2 is for channel 2.

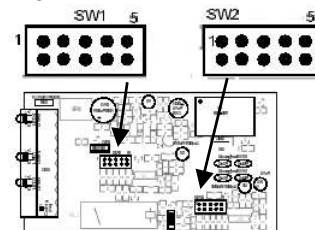

Output Table 2 Selection C204 PCB

Output	1	2	3	4	5
4-20mA	X		X		
0-20mA		X			
0-5V		X			X
1-5V	X		X		X
0-10V		X		X	

X = coding plug inserted

Type No. Designation DI739 – X XX X XX X X X

Supply:

- 1 = 80-300Vdc / 80 – 280Vac.
- 2 = 10-60Vdc / 16 – 42Vac

Input 1:

See input codes.

Output 1:

- 1 = Link selectable (default 4-20mA).
- *) 9 = Other specify

Input 2:

- 21 to 70 see input codes.
- *) 71 = Range splitting (specify split point)
- *) 72 = Splitter (one input, two outputs)

Output 2:

- 1 = Link selectable (default 4-20mA).
- *) 9 = Other specify

Option:

- 0 = none.
- *) 2 = Customised response time.

Alarm:

- 0 = Not fitted.
- *) 1 = Channel 2 change over 1% hysteresis.

CH1 and CH2 Input Codes

Specify calibration details for all inputs.

- *) 21 = DC voltage 2kV max.
- *) 22 = DC millivolt, <100mVdc.
- *) 23 = Bipolar voltage 10mV to ± 2 kV.
- *) 24 = DC current 10A max.
- *) 30 = AC voltage 10mV to 500V span.
- *) 32 = True r.m.s.
- *) 33 = Thermocouple input.
- *) 34 = RTD input.
- *) 35 = Frequency input. (Sine, Triangle, Square, Pulse).
Cal range: 0-10Hz 0 - 5kHz. Sensitivity: 200mVpp. (70mV r.m.s.) min. 22Vpp. max.
- *) 36 = Frequency (NAMUR, contact).
- *) 37 = Frequency (NPN Prox 20V).
- *) 38 = Frequency (PNP Prox 20V).
- *) 39 = Resistance input (constant current excitation).
- *) 40 = Conductivity 50uS/cm to 100mS/cm (k=1.0)
- *) 41 = pH/ORP electrode
- *) 42 = Potentiometer 3W voltage excited.
- *) 43 = Watermark Soil Moisture Sensor SMS009.
- *) 61 = Adder, 2 inputs 4-20mA floating #.
- *) 62 = Subtractor, 2 inputs 4-20mA floating #.
- *) 64 = MIN selector, 2 inputs 4-20mA floating #.
- *) 65 = MAX selector, 2 inputs 4-20mA floating #.
- *) 99 = Other.

About Range Splitting (Input 2 option 71)

Only one input is connected with two outputs. The split point (SP) must be specified when ordering and is typically set at 0.5.

If SP = 0.5 then 0-50% IN = 0-100% OUT1 and 50-100% IN = 0-100% OUT2.

About Input Options 61 to 65

The adder, subtractor, MAX and MIN options are per channel (two signals entering one channel). For isolated adding and subtracting use the SFI762 module.

= Signals connected to floating inputs must be electrically isolated from each other.

*) Price Extra..

In the interest of development and improvement, A.P.C.S. Pty. Ltd. reserve the right to amend, without notice, details contained in this publication. A.P.C.S. PTY. LTD. will accept no legal liability for any errors, omissions or amendments.