

DUAL PROCESS ALARM (v1) DPA203

DESCRIPTION

As part of the A.P.C.S. Series 200 modular range of alarms the DUAL PROCESS ALARM DPA203 offers an economical solution to applications combining alarming and compactness with accuracy and flexibility. Due to its total width of only 22.5mm and the 35mm DIN-Rail mounting arrangement the DPA203 is ideal for "nestmounting" in field enclosures or as a "space saver" in larger control cabinets. The DPA203 is a dual trip alarm module for a variety of sensors; low level DC or AC signal input with two independently adjustable trip points, providing two voltage free contacts rated at 8A/250V. Power supply can be 12 or 24Vdc or low level (non-isolated) AC voltage. Double surge protection is standard as with all Series 200 modules to prevent failure due to spikes induced by DC switched inductive loads. The DPA203 is designed to accept most types of sensors or any type of electrical signal as an input. There are nine different types of input cards available (inputs listed overleaf). These pluggable input conditioning cards are fully interchangeable with other Series 200 modules simplifying field modification. Input range calibration is set by metal film resistors on solder lugs located on the input card. The AC current input has a small transformer fitted, providing 2kV input to supply isolation. The trip point is adjustable by 15-turn potentiometers from the front of the unit by simulation of the input signal. Switching hysteresis (dead band) is normally factory set to 1% of range to prevent contact chatter. Trip status is indicated by a red L.E.D. on the front. Direct or reverse action is selectable internally by solderless coding plugs. A retransmit output signal (0 - 1Vdc) from the input section is available as an option.

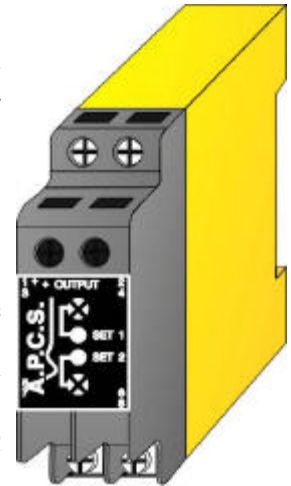

General Specifications

Size:	22.5W x 68H x 120D (mm).
Mounting:	Clip for 35mm DIN-Rail Housing
Material:	Polycarbonate.
Connection:	Screw terminals.
Weight:	0.120 kg.
Protection class:	IP40 (IP65 Enclosure opt.)
Repeatability:	0.1% of range
Input types:	mV, Thermocouple, RTD, AC-Volts, AC-Current, frequency, DC Pulse, pH/ORP, Resistance.
Temperature drift of trip point:	0.01% / °C within operating range.
Ambient operating range:	-20...+70°C
Relay contacts:	Normally open or normally closed 8A/250Vac resistive 3.5A/250Vac inductive.
Switching hysteresis (DB):	1% (can be factory configured).
Power supply swing:	-20...+30% (24Vdc supply).
Input to contact isolation:	2kV.
Input to power isolation:	None, sensor common connects to supply common. For AC current 2kV (internal CT).
Electromagnetic compatibility:	Complies with AS/NZS 4251.1 (EN 50081.1)

Block Diagram

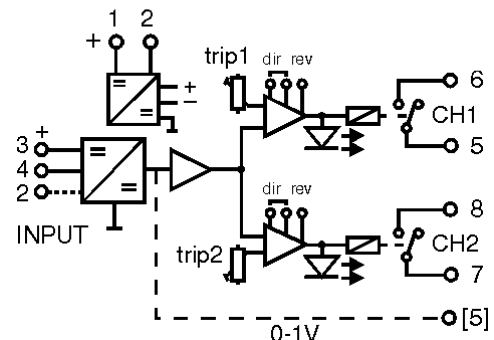

For input / output combinations refer to TYPE NO. DESIGNATION overleaf.

TYPE NO. DESIGNATION

DPA203 - X X X X

Power Supply: (non-isolated)

- 1 = 12Vdc (10 - 50mA).
- 2 = 24Vdc (10 - 50mA).
- *) 5 = Other <48V dc/ac (Specify).
- 3 = 12Vac.
- 4 = 24Vac.

Input:

NOTE:- Specify type of sensor and calibration details.

- *) 1 = Millivolts DC (2mV up to 100mV) for >100mV see DPA202.
- *) 2 = Thermocouple.
- *) 3 = RTD, Pt100.
- *) 4 = Volts AC (10mV up to 1kV non-isolated from supply).
- *) 5 = Frequency, pulse (10Hz up to 5kHz).
- *) 6 = pH/ORP electrode (>100M Ω).
- *) 7 = Resistance 2-wire constant current excited.
- *) 9 = Other (Specify).

Trip Action and Contact Configuration:

(Trip Action change by coding plug, contact by solder connection).

- 1 = Both CH Dir (High) Contacts N/O.
- 2 = Both CH Dir (High) Contacts N/C.
- 3 = Both CH Dir (High) CH1 N/O, CH2 N/C.
- 4 = Both CH Rev (Low) Contacts N/O.
- 5 = Both CH Rev (Low) Contacts N/C.
- 6 = Both CH Rev (Low) CH1 N/O, CH2 N/C.
- 7 = CH1 Dir (High), CH2 Rev (Low) Contacts N/O.
- 8 = CH1 Dir (High), CH2 Rev (Low) Contacts N/C.
- *) 9 = Other (Specify).

Definitions

Dir = Direct acting
 relay energises with input above setpoint
 Rev = Reverse acting
 relay energised with input below setpoint
 Contact N/O: Normally open - open when relay de-energised.
 Contact N/C: Normally closed - closed when relay de-energised

Options:

- 0 = None.
- 1 = Open collector transistor output.
- *) 2 = Process retransmission (0 - 1Vdc).
- *) 3 = Potentiometer 3W voltage excited.
- *) 9 = Other (Specify).

FRONT CONTROL EXPLANATION

- 1) Status indicator CH1 ON - relay energised.
- 2) Status indicator CH2 ON - relay energised.
- 3) Trip set - adjust 15 turns.

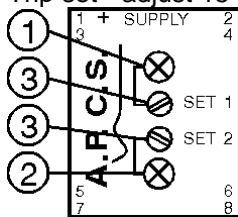

Connection Diagram

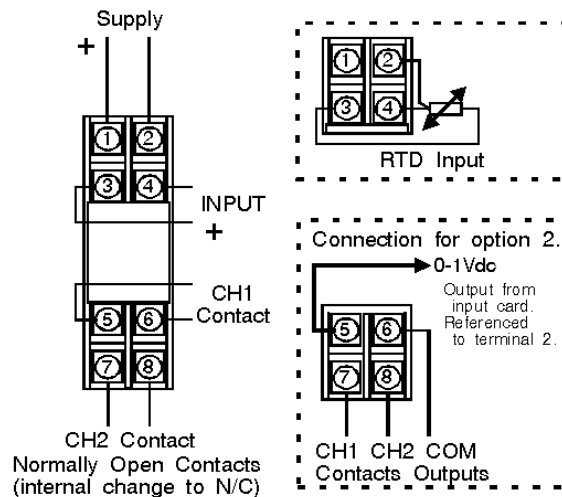

*) Price Extra

In the interest of development and improvement, A.P.C.S. Pty. Ltd. reserve the right to amend, without notice, details contained in this publication. No legal liability will be accepted by A.P.C.S. Pty. Ltd. for any errors, omissions or amendments.