

DUAL PROCESS ALARM (v1) DPA202

DESCRIPTION

As part of the A.P.C.S. Series 200 modular range of alarms the DUAL PROCESS ALARM DPA202 offers an economical solution to applications combining alarming and compactness with accuracy and flexibility. Due to its total width of only 22.5mm and the 35mm DIN-Rail mounting arrangement the DPA202 is ideal for "nestmounting" in field enclosures or as a "space saver" in larger control cabinets. The DPA202 is a dual trip alarm module with two independently adjustable trip points, providing two voltage free contacts rated at 8A/250V. Power supply can be 12 or 24Vdc or low level (non-isolated) AC voltage. Double surge protection is standard as with all Series 200 modules to prevent failure due to spikes induced by DC switched inductive loads. The DPA202, designed to accept DC voltage and DC current inputs accommodates a wide range of process signals. The voltage input version covers a range of 0.1 up to 100Vdc and references to the DC supply common. The current input version covers a range of 1mA up to 1000mA and uses a DC-shunt resistor on the input circuit to generate a voltage signal of typically 1V (eg. 47 Ω for 20mA). This voltage is then transferred to a high impedance differential input stage. In this way the DPA202 can be connected in series mode as is usually required in current loops without causing unwanted ground connections. The trip point is adjustable by 15-turn potentiometers from the front of the unit by simulation of the input signal. Switching hysteresis (dead band) is normally factory set to 1% of range to prevent contact chatter. Trip status is indicated by a red L.E.D. on the front. Direct or reverse action is selectable internally by solderless coding plugs.

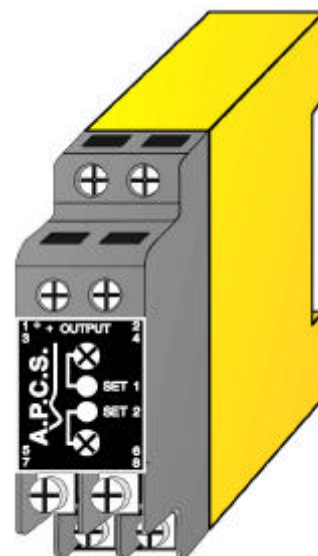

General Specifications

Size:	22.5W x 68H x 120D (mm).
Mounting:	Clip for 35mm DIN-Rail.
Housing material:	Polycarbonate.
Connection:	Screw terminals.
Weight:	0.100 kg.
Protection class:	IP40 (IP65 Enclosure opt.)
Repeatability:	0.1% of range.
Input range:	100mV up to 100Vdc or 1mA up to 1000mA DC.
Temperature drift of trip point:	0.01% /°C within operating range.
Ambient operating range:	-20...+70°C.
Relay contacts:	Normally open or normally closed. 8A/250Vac resistive. 3.5A/250Vac inductive.
Switching hysteresis (DB):	1% (can be factory configured).
Power supply swing:	-20...+30% (24Vdc supply).
Input to contact isolation:	2kV.
Input to power isolation:	On voltage inputs the input common connects to supply common. (Differential voltage input on request). Input current has 70dB DC CMRR to supply common.
Current shunt common mode voltage range:	-9 to +27V.
Electromagnetic compatibility:	Complies with AS/NZS 4251.1 (EN 50081.1)

Block Diagram

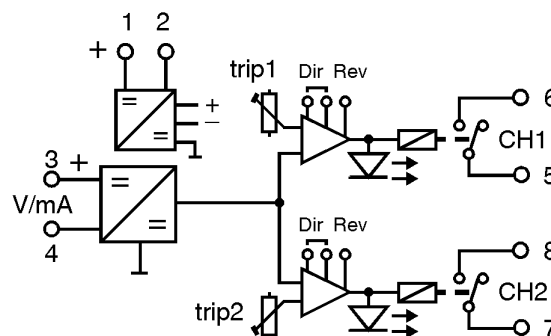

For input / output combinations refer to TYPE NO. DESIGNATION overleaf.

TYPE NO. DESIGNATION

DPA202 - X X X X

Power Supply: (non-isolated)

- 1 = 12Vdc (10mA - 50mA).
- 2 = 24Vdc (10mA - 50mA).
- 3 = 12Vac
- 4 = 24Vac

- *) 5 = Other <48Vdc/ac (Specify).
- 6 = Signal Power 10 - 20Vdc.
- 7 = Signal Power 20 - 30Vdc.
- *) 8 = Signal Power Other.

Input:

- 0 = Signal Power.
- 1 = 0 - 0.1V (100k Ω).
- 2 = 0 - 1V (100k Ω).
- 3 = 0 - 2V (100k Ω).
- 4 = 0 - 5V (200k Ω).
- 5 = 0 - 10V (500k Ω).
- 6 = 0 - 1mA (1k Ω).
- 7 = 0 - 10mA (100 Ω).
- 8 = 0 - 20mA, 4 - 20mA (47 Ω).
- *) 9 = Other (Specify).

Trip Action and Contact Configuration:

(Trip Action change by coding plug, contact by solder connection).

- 1 = Both CH Dir (High) Contacts N/O.
- 2 = Both CH Dir (High) Contacts N/C.
- 3 = Both CH Dir (High) CH1 N/O, CH2 N/C.
- 4 = Both CH Rev (Low) Contacts N/O.
- 5 = Both CH Rev (Low) Contacts N/C.
- 6 = Both CH Rev (Low) CH1 N/O, CH2 N/C.
- 7 = CH1 Dir (High), CH2 Rev (Low) Contacts N/O.
- 8 = CH1 Dir (High), CH2 Rev (Low) Contacts N/C.
- *) 9 = Other (Specify).

Definitions

Dir = Direct acting.
 relay energises with input above setpoint.
 Rev = reverse acting.
 relay energised with input below setpoint.
 Contact N/O: Normally opens - open when relay de-energised.
 Contact N/C: Normally closed - closed when relay de-energised.

Options:

- 0 = None.
- 1 = Open collector transistor output.

*) 9 = Other (Specify).

Connection Diagrams

FRONT CONTROL EXPLANATION

- 1) Status indicator CH1 ON - relay energised.
- 2) Status indicator CH2 ON - relay energised.
- 3) Trip set - adjust 15 turns.

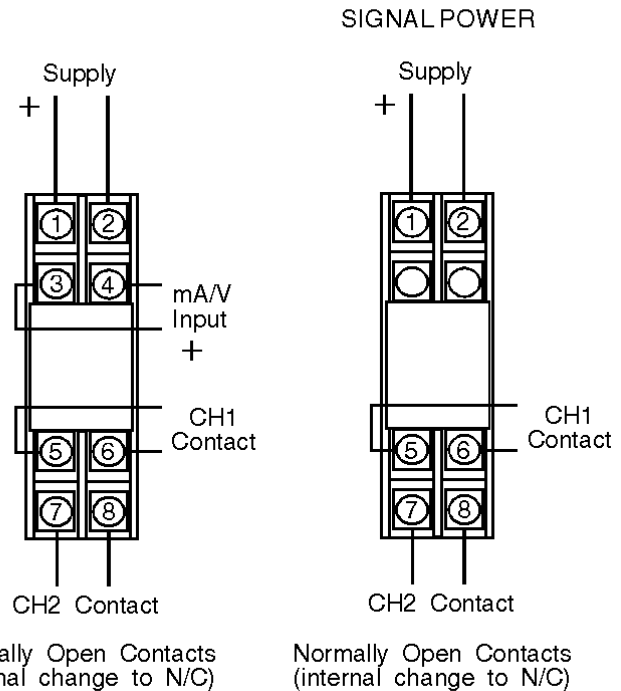
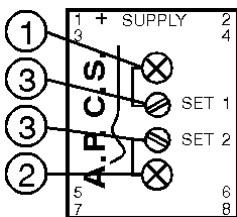

*) Price Extra.

In the interest of development and improvement, A.P.C.S. Pty. Ltd. reserve the right to amend, without notice, details contained in this publication. A.P.C.S. PTY. LTD. will accept no legal liability for any errors, omissions or amendments.