

### About The Sensor

The module must be pre calibrated to accept a particular sensor type (Piezo accl, swing coil, eddy current, etc). After the sensor type is set, calibration is a simple matter of scaling the voltage from the sensor to the scale you require. If using a PR337F04 or PRM603C01, PRM608A11 quartz shear accelerometer, the sensor provides 100mV/g. If the sensor were operating at  $\pm 25g$ , then the signal from the sensor would be  $25 \times 100 = \pm 2.5V$ .

### Internal Pre Scaling

Modules using the "901-042 VBT-C142 ASSY" have a internal header to set the mV scale required. This assembly can be identified from 100-C142 etched onto the circuit board. Older vibration cards do not have a pre scale header and are factory set.

### Set Links On Header J1. (C142 Assy only)

Header J1 must be be set to the required span range. The unit must then be disconnected, opened to set links on J1.

mVpeak	J1 setting**			
	1	2	3	4
200	x	x	x	x
400	-	-	-	x
500	x	x	x	-
1000	x	x	-	-
2000	x	-	-	-
5000	-	-	-	-

Note. \*\* "-" = link open, "x" = link closed.

### Calibration Procedure

1. Connect power supply, input and outputs according to the connection diagram. Apply input to terminals 10 (+) and 9 (-). Calibration is performed by either using the sensor signal or by using a function generator.
2. The front mounted BNC connector ① provides a buffered retransmit of the raw vibration signal.
3. When calibrating by using the sensor signal;
  - measure the signal with a volt meter or CRO via the BNC connector. If using a volt meter the r.m.s. readings must be converted to 0-peak multiplying by  $\sqrt{2}$
  - If the required millivolts for full-scale acceleration can be applied then measure between the test socket ③ and terminal 9 and adjust the potentiometer ② for 2Vdc.

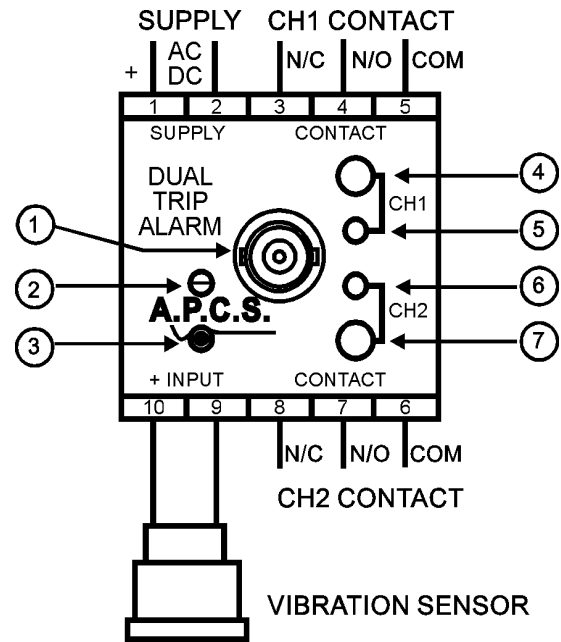

- 
- If only a percentage of full-scale millivolts can be applied then measure between the test socket ③ and terminal 9 and adjust the potentiometer ② for "full-scale%" x 2Vdc.

4. When calibrating by using a function generator;
    - Apply the level of peak voltage that relates to the maximum vibration as specified by your sensor.
    - Measure between the test socket ③ and terminal 9 and adjust the potentiometer ② for 2Vdc.
- e.g. When using a ACCELEROMETER with 100mV/g and full scale is to be set at  $\pm 20g$ , then the input required when setting the potentiometer for  $\pm 2Vdc$  at point ③ is  $100mV \times 20 = \pm 2V$ .
5. To set the CH1 trip relay apply the required voltage or stimulate the sensor at the required level and adjust the trip potentiometer ⑤ until the led ④ turns on and the contacts at terminals 3,4,5 change state.
  6. To set the CH2 trip relay apply the required voltage or stimulate the sensor at the required level and adjust the trip potentiometer ⑥ until the led ⑦ on and the contacts at terminals 6,7,8 change state.

In the interest of development and improvement, A.P.C.S. Pty. Ltd. reserve the right to amend, without notice, details contained in this publication. A.P.C.S. PTY. LTD. will accept no legal liability for any errors, omissions or amendments.