

DESCRIPTION

The BIPOLAR SIGNAL CONVERTER BSC133 has been designed to produce a bipolar output signal from any type of input signal. This low cost module matches the Series 100 range and is suitable for all standard AC and DC power supply voltages. Input signals can be bipolar or unipolar process signals such as -10, +10V or 4 - 20mA. A special input conditioning card (optional) permits the use of the BSC133 for low level, AC or sensor inputs. The 4 - 20mA input version also features a 24Vdc (25mA) auxiliary supply output to operate loop-powered transmitters connected to its input. Refer to A.P.C.S. Series 200 and 500 for details on loop-powered transmitters. The output drive circuit is factory configured to provide load independent voltage or load independent bipolar current output. Maximum current drive for voltage output is 50mA at $\pm 20V$ output. Applications requiring output $>50mA$ up to 2A as is the case with hydraulic drive solenoids can be accommodated using an external bipolar DC-power supply. Models with outputs above 50mA output have an external heatsink. Final calibration is trimmed using the front accessible 'offs' and 'span' 15-turn trim adjustments. The output signal level is indicated by a green L.E.D. on the front, giving a clear indication of module function. All units are fitted with a 0.1 second filter. This filter constant can be increased or decreased if required. RF and power transient protection is also standard as with all A.P.C.S. modules. The input/output mode can be factory configured for direct or reverse action. The basic BSC133 does not provide galvanic isolation from input to output. Refer to Bipolar Signal Isolator BS1134 for input/output isolation. Various power supply choices are available ranging from 240Vac down to 8Vdc, all provide power isolation.

**General Specifications**

Size:	52 W x 70 H x 110 D (mm).
Mounting:	DIN-Rail, gear plate.
Termination:	Screw terminals on front.
Protection class:	IP40 (IP65 Enclosure opt.)
Weight:	0.300 kg.
Dimensions standard:	52 x 70 x 110mm.
Dimensions 100mA output version:	Width increases from 52 to 85mm.
Housing material:	Polycarbonate.
Accuracy:	0.2% of span.
Front 'OFFS' adjust:	$\pm 25\%$ typical
Front 'SPAN' adjust:	$\pm 25\%$ typical
Temperature effect:	0.01% per $^{\circ}C$.
Operating temperature range:	$-10...+60^{\circ}C$.
Output load effect:	less than 0.25% up to max. load.
Output loop drive:	$\pm 10mA$ into 0 - 2000 Ω $\pm 20mA$ into 0 - 1000 Ω
Output voltage load:	$\pm 10V$ into 200 Ω minimum. $\pm 20V$ into 400 Ω minimum. 10 minutes max.
Input/output isolation:	None (use BS1134).
Power requirements:	ac supply 4W, dc supply 3W.
Power supply isolation:	2kV r.m.s.
Electromagnetic compatibility:	Complies with AS/NZS 4251.1 (EN 50081.1) 

For input / output combinations refer to TYPE NO. DESIGNATION overleaf.

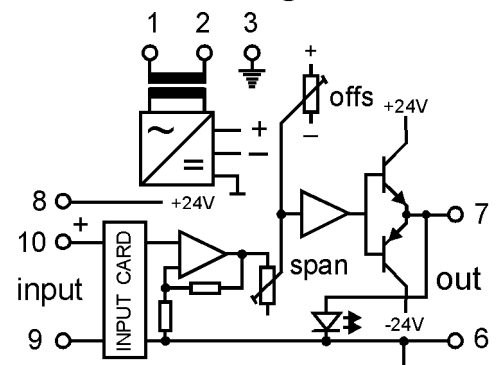
Block Diagram

TYPE NO. DESIGNATION

Power Supply:

- | | |
|-------------------------|------------------------------|
| 1 = 240V, 50/60Hz ±10%. | *) 6 = 8 - 60Vdc Isolated. |
| 2 = 120V, 50/60Hz ±10%. | *) 7 = 48Vdc (use '6'). |
| 3 = 24V, 50/60Hz ±10%. | *) 8 = 60 - 240Vdc Isolated. |
| *) 5 = 12Vdc (use '6'). | *) 9 = Other (Specify). |

Input:

- | | | |
|----------------------|-----------------------------|-------------------------------|
| Unipolar | | Bipolar |
| 01 = 0 - 100mV (1M). | 11 = 0 - 100µA (1k). | 21 = ±1V (1M). |
| 02 = 0 - 200mV (1M). | 12 = 0 - 1mA (1k). | 22 = ±5V (1M). |
| 03 = 0 - 500mV (1M). | 13 = 0 - 5mA (220R). | 23 = ±10V (1M). |
| 04 = 0 - 1V (1M). | 14 = 0 - 10mA (100R). | 24 = ±20V (1M). |
| 05 = 0 - 2V (1M). | 15 = 0 - 20mA (51R). | *) 25 = 3-wire Potentiometer. |
| 06 = 0 - 5V (1M). | 16 = 0 - 50mA (20R). | (Data sheet: DS13355). |
| 07 = 0 - 10V (1M). | #) 17 = 4 - 20mA (51R). | |
| 08 = 0 - 20V (1M). | 18 = 10 - 50mA (20R). | |
| 09 = 0 - 50V (1M). | *) 19 = CARD (See options). | |
| 10 = 0 - 100V (1M). | *) 20 = Other (Specify). | |

Output:

- | | |
|-----------------------------|-----------------------------|
| 1 = -1...+1V (25 Ω min). | 5 = -1...+1mA (20k Ω max). |
| 2 = -5...+5V (100 Ω min). | 6 = -5...+5mA (4k Ω max). |
| 3 = -10...+10V (200 Ω min). | 7 = -10...+10mA (2k Ω max). |
| 4 = -20...+20V (400 Ω min). | 8 = -20...+20mA (1k Ω max). |
| | *) 9 = Other (Specify). |

Action:

- | | |
|--------------------|---------------------|
| 1 = In/Out Direct. | 2 = In/Out Reverse. |
|--------------------|---------------------|

Output Options:

- | | |
|---|---|
| 0 = None. | *) 4 = Output 2A – 5A External bipolar supply |
| *) 1 = Output ramp | *) 5 = External ratio 0.5 - 1.5 |
| *) 2 = Output 50 - 500mA
External bipolar supply | *) 6 = Auxiliary supply 24Vdc/25mA max |
| *) 3 = Output 500mA - 2A
External bipolar supply | *) 7 = Peak hold (max. hold 120 min) |
| | *) 8 = Track and hold (max. hold 120 min) |
| | *) 9 = Other (Specify). |

Input Options:

NOTE:- Specify type of sensor and calibration details.

- | |
|--|
| 00 = None. |
| *) 01 = RTD input (Pt100 20...400°C span). |
| *) 02 = mV input (up to 100mVdc span). |
| *) 03 = Thermocouple input (all types 4-80mV span). |
| *) 04 = AC voltage (5mV up to 50V). |
| *) 05 = AC current (0.5 up to 10A isolated using internal CT). |
| *) 06 = Resistance 2W const. current exc. (5Ω to 5kΩ). |
| *) 07 = pH/ORP electrode input (>100M Ω). |
| *) 08 = Frequency (sine) input (5Hz up to 5kHz Span). |
| *) 09 = DC pulse input (5Hz up to 5kHz Span). |
| *) 10 = Floating differential. |
| *) 11 = Adder or Subtractor (2 x 4-20mA floating). |
| *) 17 = Load cell input. |
| *) 18 = L.V.D.T. Input. |
| *) 21 = Dither for hydraulic applications. |
| *) 99 = Other (Specify). |

Includes 24Vdc/25mA auxiliary supply on terminal 8.

*) Price Extra.

In the interest of development and improvement, A.P.C.S. Pty. Ltd. reserve the right to amend, without notice, details contained in this publication. A.P.C.S. PTY. LTD. will accept no legal liability for any errors, omissions or amendments.

Connection Diagrams

