

Power Driver (v2) PD121

The PD122 and PD121 are, dc powered, 4-wire signal-conditioning modules.

- ✓ If wanting a controlled voltage output then use a PD122
- ✓ If wanting an isolated input, a controlled current output and the output load is fully independent of the power supply then use a PD122.
- ✓ If wanting a controlled current output and one terminal of the load is connected to supply negative then a PD121 MUST be used.

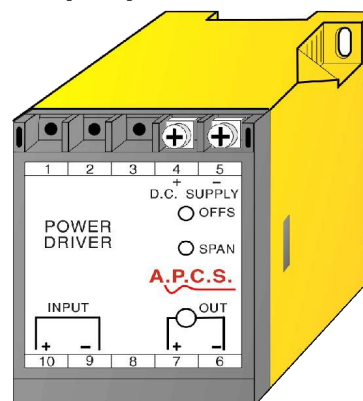

FEATURES:

- **High Power Output** for applications where an output drive of 100mA (24V) up to 2A_{dc} is required, as is common with hydraulic solenoid drive applications.
- **Signal conversion** from all commonly used process control signals.
- **Signal inversion** for applications where the output has to decrease for increasing input (Reverse action).
- **Signal filtering** for fluctuating input signals. The "Ramp option" allows for the time constant to be selected by the user.
- **Gain and bias** (scaling) adjustments to amplify or zero shift a portion of the input signal.
- **Dither option.** A low level AC signal is superimposed on the output to prevent the output valve or hydraulic solenoid from becoming stuck in applications where the valve is stationary for long periods of time (the amplitude and frequency of the dither signal are specified for the application).

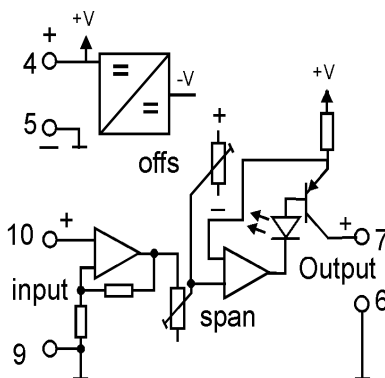

Power supplies for the standard PD121 include 12V_{dc} and 24V_{dc} (other on request). The PD121 module features a wide range of input and output signals, direct and reverse action, including bipolar input. For bipolar output use Bipolar Signal Converter BSC133. Input signals range from 0.1V to 100V_{dc} and 100mA to 1A_{dc}. All units are factory calibrated to customer specification but can be trimmed to final requirements by the SPAN and OFFSET controls (15-turn trimmers) located on front. The output signal level is indicated by a green L.E.D. on the front, giving a clear indication of module function, presence of signal and output loop continuity. All units are fitted with a 0.1 second filter. This filter constant can be increased or decreased if required. RF and power transient protection is also standard as with all A.P.C.S. modules.

General Specifications

Size:	52 W x 70 H x 110 D (mm). (85mm wide with heat sink).
Mounting:	DIN-Rail, gear plate.
Termination:	Screw terminals on front.
Protection class:	IP40 (IP65 Enclosure opt.)
Weight:	0.300 kg.
Housing material:	Polycarbonate.
Accuracy:	0.2% of span.
Temperature effect:	0.01% per °C.
Operating temp. range:	-10...+60°C.
Output load effect:	less than 0.2% up to max. load.
Output loop drive:	100mA into 0 - 180Ω.
(24V _{dc} supply)	500mA into 0 - 36Ω. 1A into 0 - 18Ω.
Input/output isolation:	none, use cascaded signal isolator SI231 or consider using PD122.
Electromagnetic compatibility:	Complies with AS/NZS 4251.1 (EN 50081.1) ✓

For input / output combinations refer to TYPE NO. DESIGNATION overleaf.

TYPE NO. DESIGNATION

PD121 - X XX X X XX

Power Supply:

- 1 = 12VDC, $\pm 10\%$ The power supply is not isolated from the input or the output.
 2 = 24VDC, $\pm 15\%$ *) 9 = Other (Specify).

Input:

- | | | |
|-------------------------------|-------------------------------|-------------------------|
| 04 = 0 - 100mV (470k). | 12 = 0 - 5mA (240 Ω) | 21 = $\pm 1V$ (100k). |
| 05 = 0 - 200mV 470k). | 13 = 0 - 10mA (100 Ω) | 22 = $\pm 5V$ (470k). |
| 06 = 0 - 500mV (470k). | 14 = 0 - 20mA (100 Ω) | 23 = $\pm 10V$ (1M). |
| 07 = 0 - 1V (470k). | 15 = 0 - 50mA (50 Ω) | 24 = $\pm 20V$ (1M). |
| 08 = 0 - 2V (470k). | 16 = 4 - 20mA (100 Ω) | *) 25 = 3-Wire pot |
| 09 = 0 - 5V (1M). | 17 = 10 - 50mA (5 Ω) | |
| 10 = 0 - 10V (1M). | 18 = 0 - 100mA (1k). | |
| 11 = 0 - 1mA (470 Ω). | 19 = 0 - 1A (1 Ω) | |
| | *) 20 = Other (Specify). | *) 99 = Other (Specify) |

Output:

24Vdc SUPPLY

- 1 = 0 - 100mA (180 Ω max). *) 6 = 0 - 1.2A (15 Ω max).
 2 = 0 - 200mA (90 Ω max). *) 7 = 0 - 1.5A (12 Ω max).
 3 = 0 - 500mA (36 Ω max). *) 8 = 0 - 2A (9 Ω max).
 *) 4 = 0 - 750mA (27 Ω max). *) 9 = Other (specify).
 *) 5 = 0 - 1A (18 Ω max).

Action:

- 1 = Direct. 2 = Reverse.

Options:

- 00 = None
 *) 04 = Output ramp.
 09 = Extended range on "OFFS" and SPAN" front panel trim pots. Range specified by the customer.
 *) 14 = Dither for hydraulic applications.
 *) 15 = External Gain and Bias, specified by the customer.
 *) 99 = Other (specify).

Separate Heatsink Models

All models with an output above 500mA use a separate heatsink (105mm x 135mm) for current up to 2.5A; or *(225 x 105) for currents up to 5A. This heatsink must be mounted in an area with adequate ventilation. The pass transistor case is at an elevated voltage and must not be allowed to contact any objects (heatsink is isolated).

Side Mounting Heatsink Used up to 500mA

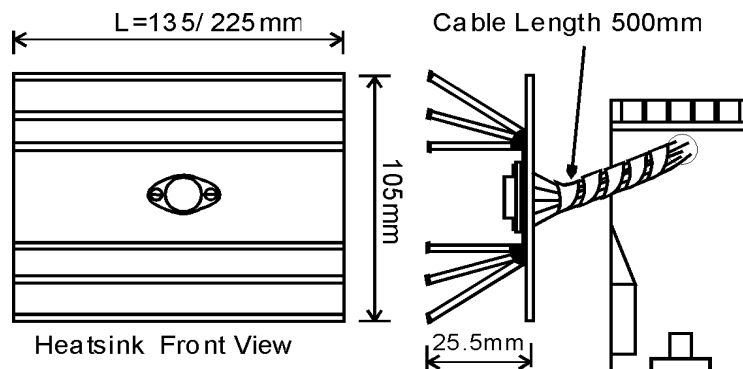
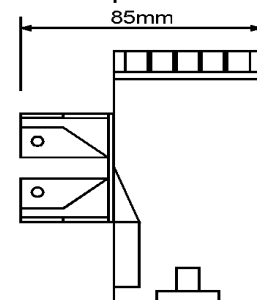

*) Price Extra..

In the interest of development and improvement, A.P.C.S. Pty. Ltd. reserve the right to amend, without notice, details contained in this publication. A.P.C.S. PTY. LTD. will accept no legal liability for any errors, omissions or amendments.