

HALL EFFECT CT 50A HCT016

Description

The Hall effect current sensor provides strong electrical isolation between the output of the sensor and the current carrying conductor. The output of the sensor reflects the real wave shape of DC, AC and pulsed currents of the primary circuit.



General Specifications

Input Current:	+/- 50Adc
Measurement Output:	+/- 5Vdc
Response time T_{90} :	$\leq 30\mu\text{s}$
Accuracy	1%
Linearity error:	$< 0.4\%$
Offset voltage	$\pm 20\text{mV}$
Hysteresis error	$\pm 10\text{mV}$
Output impedance:	100 Ω
Minimum output load:	8k2 Ω
recommended output load:	$\geq 15\text{k}\Omega$
Zero adjustment:	$\pm 2\%$
Span adjustment:	$\pm 20\%$
Temperature drift	$\leq 250\text{ppm}/^\circ\text{C}$
Current consumption	$\leq 25\text{mA}$
Power Supply:	$\pm 15\text{Vdc} \pm 5\%$ regulated
Isolation	3 kVrms / 50Hz / min
Overload:	1000A
Operating temperature range	$-10^\circ\text{C} \sim +80^\circ\text{C}$
Storage temperature range	$-25^\circ\text{C} \sim 85^\circ\text{C}$
Fire retardancy	UL94-V0

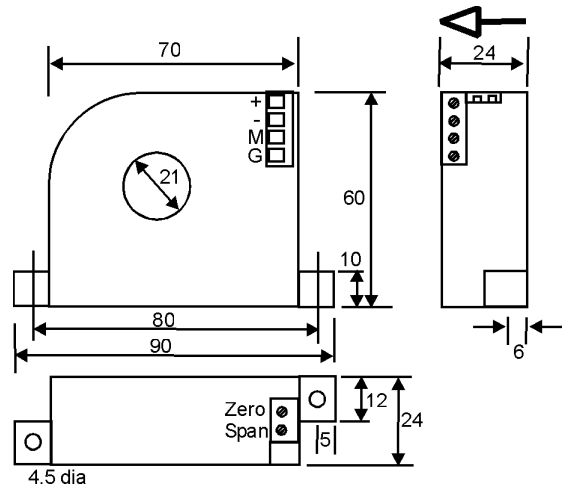

Application

The HCT016 is designed for use with the DCT247. The DCT247 is a din mounted signal conditioning module for monitoring of DC and true RMS AC currents and provides a standard process signal output or relay contact.

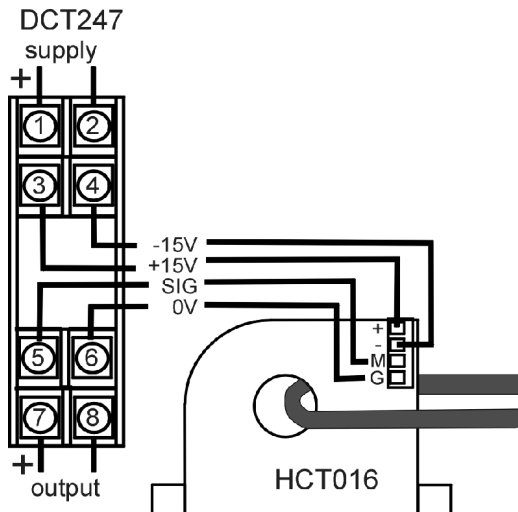

In the interest of development and improvement, A.P.C.S. Pty. Ltd. reserve the right to amend, without notice, details contained in this publication. A.P.C.S. PTY. LTD. will accept no legal liability for any errors, omissions or amendments.